

# PanelMate® Inserts

## The fast and economical way to anchor in concrete or wood

This new product from Elco Construction Products is a quick and easy way to provide a 1/4-20 internally-threaded anchoring base in concrete or wood. Originally designed for installing hurricane panels, these versatile anchors can be used wherever 1/4-20 threaded hardware needs to be attached to concrete or wood. The PanelMate® insert is designed to be permanently installed, allowing one time or multiple insertions of 1/4-20 threaded components.

### Features & Benefits

- Simple installation: in concrete, use a standard 7/16" ANSI masonry bit†. In wood use a standard 7/16" (.437") wood or steel bit. Drill the hole and install the anchor. No special countersinking tool is required.
- Special external threads provide holding power in drilled hole. Anchors do not require bearing on bottom of hole, so they will work in block even if the drilled hole enters the block cavity.
- Two lengths:
  - 2-1/8" for applications with a stucco exterior
  - 1-7/16" for applications without a stucco exterior
- 1/4-20 internal threads allow use of multiple lengths of fasteners: 1-7/6" insert is fully threaded; 2-1/8" insert has 1-1/4" long internal threads.
- 5/16" internal hex drive provides strong, positive driver-bit engagement to ease installation. PanelMate® hex tools available (see other side).
- Countersinking head styles seat flush in stucco and similar materials and prevent gaps and voids around head
- Silver Stalgard® corrosion-resistant finish withstands 800 – 1,000 hours in salt spray testing per ASTM B117 standards
- Nylon locking patch on 2-1/8" insert resists back-out

†(actual diameter .458"/.468")

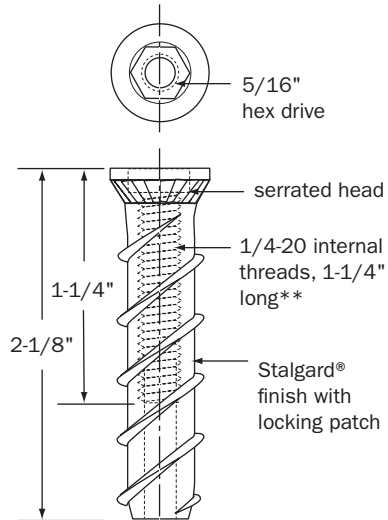

**PanelMate L Insert**

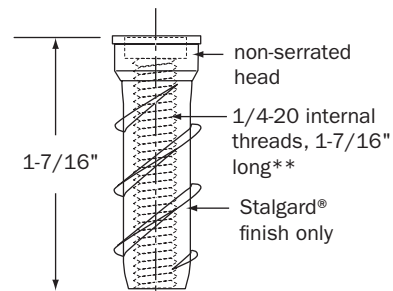

**PanelMate S Insert**

\*\*accept multiple lengths of 1/4-20 fasteners

### Specifications

	Catalog No.	Model	Insert Length	Dia.	Material	Finish
	ENX305	PanelMate® L Insert	2-1/8"	1/2"	carbon steel	Silver Stalgard® with nylon locking patch
	ENX310	PanelMate® S Insert	1-7/16"			Silver Stalgard® only

### Important Notice Regarding the Use of Washers with This Product

A common application for these parts is to attach hurricane panels to structures, using a stainless steel "Sidewalk Bolt" (SWB) to hold the panels in place. When panels are not in use, the SWB's are often left in the anchors for aesthetic reasons and to prevent loss. If this is done, the washers packaged with these anchors must be placed on each SWB. If they are not used, subsequent exposure to moisture, over a period of time, can cause corrosion. This may result in the inability to remove the SWB without also removing the anchor. The washers significantly reduce the normal back-out torque of the SWB and keep moisture (and corrosion) out of the anchor cavity.

**PanelMate® Anchoring System**

## Performance Data – PanelMate® Inserts

Poured Concrete Beam (2,700 PSI)			
Test	Edge Distance	Embedment	Ultimate Load (lbs.)
Pull-out	4"	1-5/8"	2,342

Block or CMU (2,676 PSI)				
Test	Block Type	Power Tool and Drill Bit	Embedment	Ultimate Load (lbs.)
Pull-out	Grout filled	Rotary hammer and SDS bit	1-1/2"	1,666 <sup>†</sup>

Hollow Block (1,794 PSI) <sup>††</sup>				
Test Type	Edge Distance (in.)	Embedment (in.)	Ultimate Load (lbs.)	Typical Mode of Failure
Pull-out	1-3/4"	1-1/4"	1,376	Pop-out/spall of block
Shear			1,100	Break-out of block
Pull-out	3-1/2"		1,608	Pop-out/spall of block
Shear			2,208	Break-out of block

Wood					
	Specific Gravity	Pilot Hole	Embedment	Edge Distance	Ultimate Load (lbs.)
SPF	.35	7/16" (.437")	1-5/8"	3/4"	1,115
#2SYP	.55				1,396

<sup>†</sup> In-house testing was done with pilot hole drilled using corded rotary hammer and 7/16" SDS masonry drill bit.

<sup>††</sup> In testing, the Panelmate® insert was installed and a 1/4-20 stainless steel machine screw was threaded into the insert. The test load was then applied to the machine screw. Tests done by Construction Testing Corp., Miami, FL. Test Report #CTC 06-012.

**NOTE:** These values are offered only as a guide; therefore, an appropriate safety factor should be applied to these values.

## Installation Components

Catalog No.	Model	Length "L"	Dia.	Material	Finish
ENY190	PanelMate® hex drive tool	2"	5/16" hex drive	steel	zinc plate
ENY192		3"			
ENY194		4"			

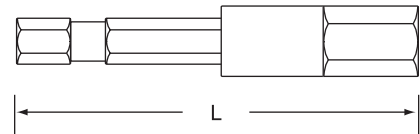

## Installation of PanelMate® Inserts

The deep 5/16" internal hex drive in the anchor provides strong, positive drive bit engagement for easy installation in concrete, masonry and wood.

### Concrete and masonry applications:

1. Pre-drill pilot hole with 7/16" ANSI masonry drill.
2. Drive in the PanelMate® insert until it seats flush. Use of an impact driver is recommended.

**NOTE:** In non-grout-filled CMU applications, masonry drill bits and hammer drills are recommended instead of SDS bits and rotary hammer drills, in order to minimize spalling of block wall

### Wood applications:

1. Pre-drill pilot hole with 7/16" drill bit (not a masonry bit).
2. Drive in the PanelMate® insert until it seats flush.

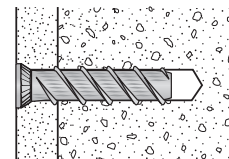

Stucco and Concrete

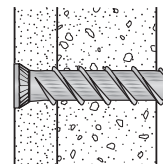

Stucco and CMU

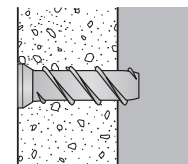

CMU only



**Elco Construction Products**  
5110 Falcon Road · Rockford, IL 61109  
**1.800.435.7213** or 815.391.5500  
Fax: 815.397.8986  
**www.elcoconstruction.com**



Distributed By: